

Customer Satisfaction Campaign 450: Replacement of Fifth Bow Latch Motor Assembly

Background

On certain cars, the fifth bow latch motor can seize, causing the top to be inoperative when using the ROOF button.

To rectify this complaint, the fifth bow latch motor should be replaced as described on the following pages.

Cars Affected:

1995- 900 Convertibles within VIN Serial No. Ranges: S7000001-V7010305

NOTE: Both 4 cylinder and V6 models are affected by this campaign.

Warranty/Time Information:

THE FOLLOWING INFORMATION MUST BE ADDED TO YOUR DCS TABLES:

FAILED PART TABLE:

FAILED OBJECT: 10450

DESCRIPTION: 5TH BOW LATCH MOTOR REPL.

MODELS: D

OPERATION NUMBER TABLE:

LABOR OPERATION: 10450

DESCRIPTION: 5TH BOW LATCH MOTOR REPL.

TRANS. TYPE: B

ENGINE TYPE: 9

DIAGNOSTIC CODE REQD: 0

MI No. 811-1758

Date June 1997

900

PI No. 5/97 Grupp 8 D 3.0

Distr. US

Customer Satisfaction Campaign 450: Replacement of Fifth Bow Latch Motor Assembly

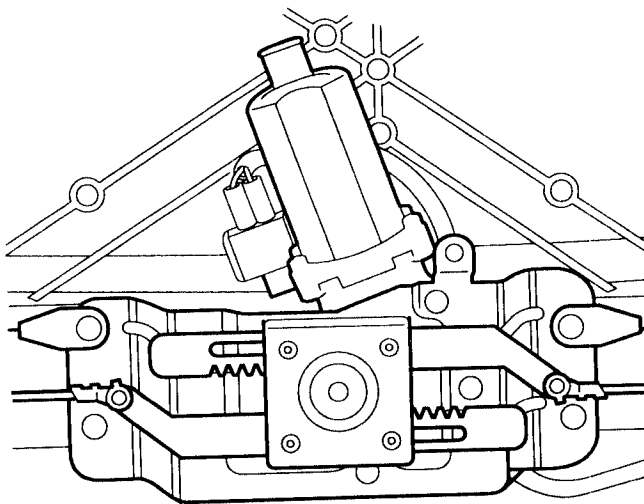

D811B028

Cars affected

Saab 900 Convertibles up to and including VIN Serial Number V7010305.

Background

On certain cars, the fifth bow latch motor can seize when the top is folded up or down. This means that the top cannot be operated using the ROOF button.

To avoid this problem, the fifth bow latch motor should be replaced as described below.

Parts required

74 97 878, spare part kit for replacement of 5th bow latch motor.

If needed:

74 97 910, plastic shouldered pins (2)

74 97 928, white plastic washers (4 = 2 per pin)

Procedure

First check whether the motor cover panel is fitted with two Torx screws(A) and that a plastic plug (B) and tape (C) are fitted to the cover panel. If the bolts or plastic plug are not fitted, proceed as described below.

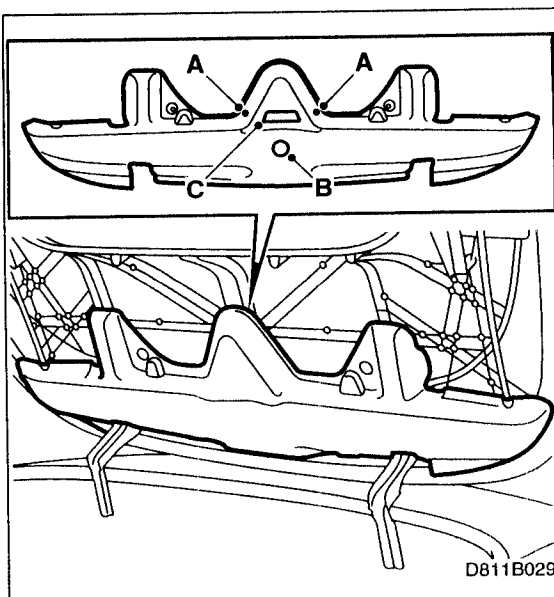

- 1 Operate the top so that the fifth bow and Tonneau cover are fully up.
- 2 Connect ISAT and move the fifth bow latch motor to the half-open position (access flaps in half-open position) using the ISAT commands:
"TSAS"
"ACTIVATE"
"LOCKING MOTOR 5th BOW"
"UP"

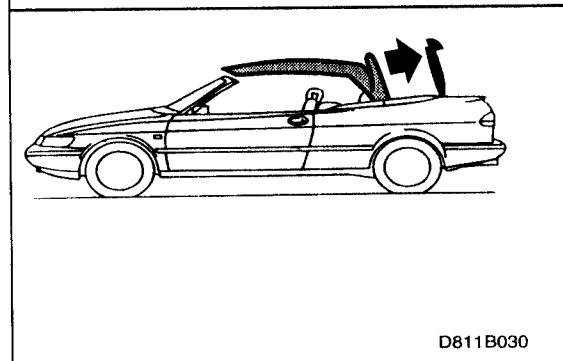

Important

This cannot be done unless you have previously changed the control module as described in SI 812-1566.

- 3 Protect the rear window and trunk lid. Insert protection under the Tonneau cover as the motor can easily drop onto the trunk lid.
- 4 Remove the cover panel.
- 5 Remove the locking rods.
- 6 Cut the cable tie holding the wiring harness and separate the connector.
- 7 Remove the four mounting bolts on the latch motor and lift out the motor.
- 8 Separate the microswitch connector on the left latch mechanism. Cut the cable tie.
- 9 Remove the two lock mechanisms for the fifth bow and place them on a work bench.

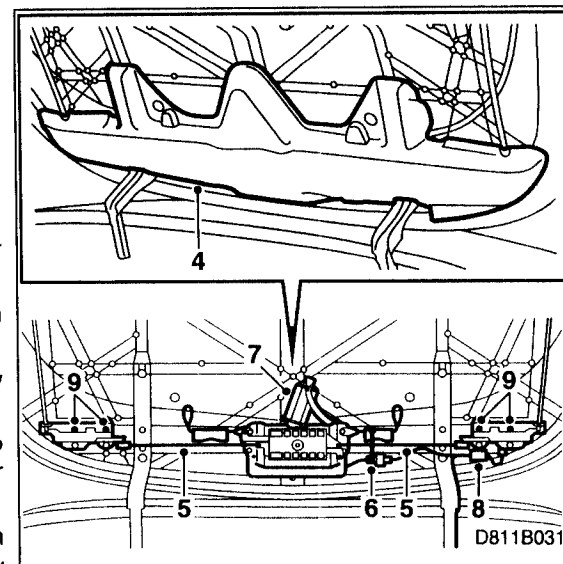

Each locking mechanism is held together using two plastic shouldered pins, P/N 74 97 910 and four white plastic washers, P/N 74 97 928 (2 per pin).

The plastic pins may in some cases be broken from use or may be damaged upon removal. They should not be required to upgrade most cars if the original press/speed nuts are cut off as instructed.

The white plastic washers may be dropped and lost when disassembling the latch but do not normally fail or wear out.

New press/speed nuts to secure the latch assembly together come in each 5th bow latch motor upgrade kit, P/N 74 97 878.

- 10 Undo the screws holding the microswitch and remove it.

Important

It is extremely important to replace the star lock washers on the lock assemblies.

Use care when removing the star washers (11). Careless removal may result in damage to the pin (12).

- 11 Undo the star lock washers by bending up the edge and cutting with pliers. Be careful not to damage the pins.
- 12 Remove the pin and take out the locking tongue. Be careful not to lose the plastic washers (4x).

- 13 Fit the new locking tongue. First insert the two plastic pins in the holder with two oval holes and place two plastic washers on these. Then add the locking tongue followed by two plastic washers. Finally add the outer holder and fit the star locking washers.

Note

The washers are not held firmly in position after fitting. They will move some.

- 14 Screw the microswitch to the holder on the left lock mechanism.

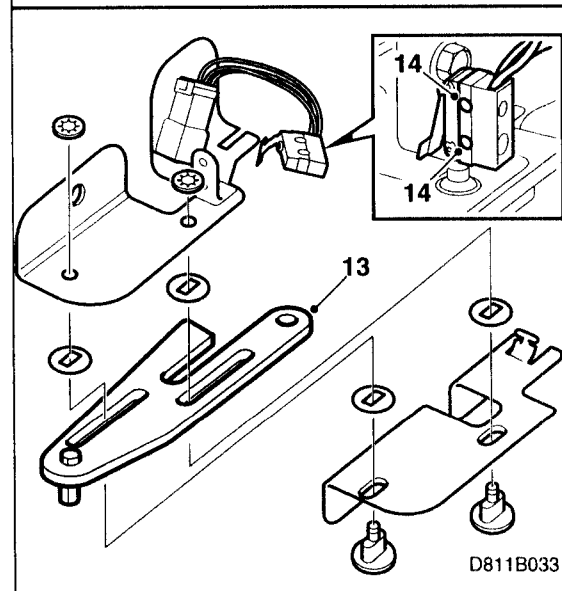
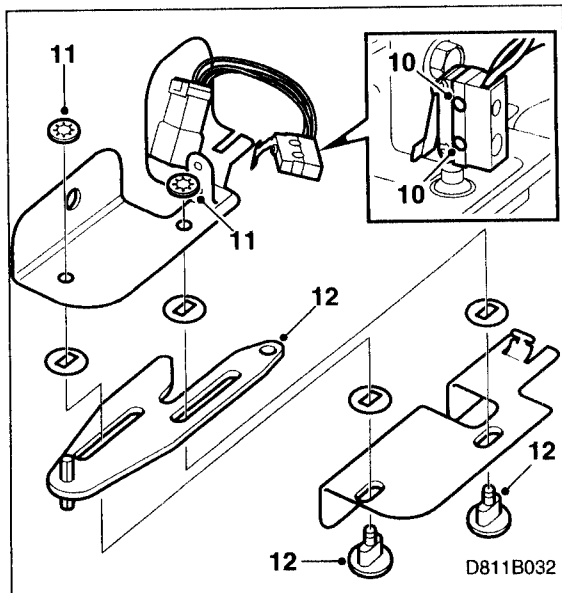

- 15 Fit the lock mechanism to the Tonneau cover. Ensure that the pin on the locking tongue lies against the wire guides for the access flaps.
- 16 Reconnect the connector on the microswitch. Fit a new cable tie.

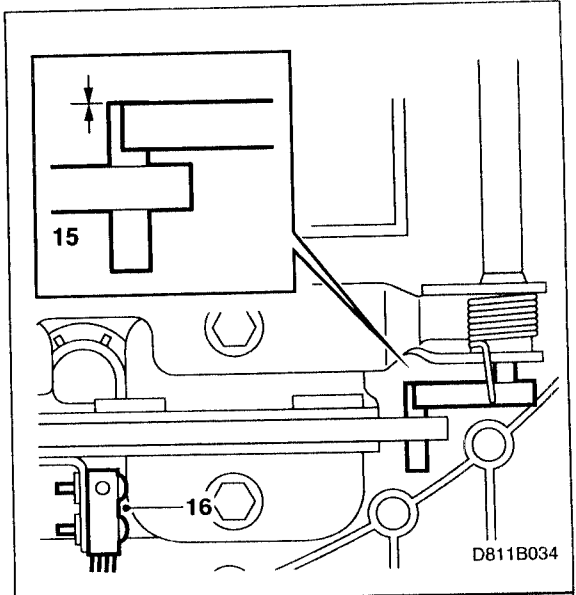

- 17 Connect the harness in the parts kit to the new motor.
 - 18 Place the motor on the Tonneau cover. Guide the cable behind the motor bracket and out on the left side of the car.
 - 19 Fit the motor and screw the impact safety wires to the top bolts of the motor bracket.
- Tightening torque: 7 Nm (5.2 lbf ft)**

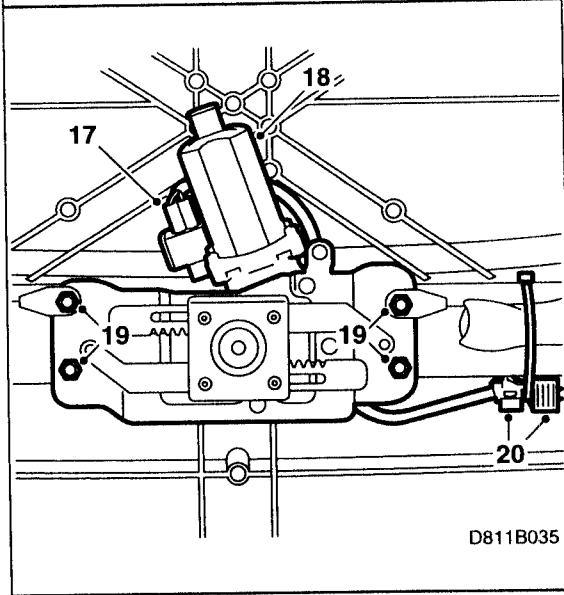

Note

The wires should run parallel with the aluminium bar.

- 20 Connect the motor harness to the car wiring harness and fit a new cable tie around the connector.

- 21 Adjust the length of the locking rods so that these measure **288 mm** from the center of the hole for the locking pin to the centered at the other end.

- 22 Fit the locking rods. Use both the old clips and the new lock washers.

- 23 Move the fifth bow locking motor to the open position (access flaps in open position) using the ISAT commands:

- "TSAS"
- "ACTIVATE"
- "LOCKING MOTOR 5th BOW"
- "UP"

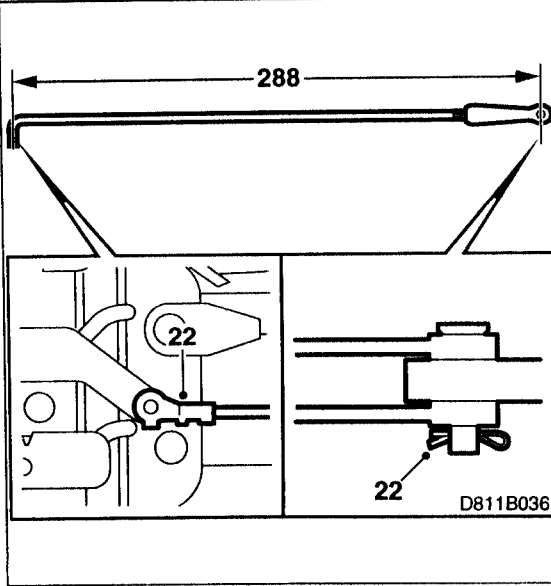

- 24 Check the locking tongue in the oval hole for the fifth bow lock. Max. 1.5 mm of the locking tab should be visible.

If the adjustment is incorrect and more than 1.5 mm of the locking tongue is visible, continue with points 25, 26 and 27. In most cases, no locking tongue will be visible through the opening.

- 25 Move the fifth bow latch motor to the closed position using the ISAT commands:

“TSAS”

“ACTIVATE”

“LOCKING MOTOR 5th BOW”

“DOWN”

- 26 Adjust the latch rods by turning to lengthen them.
- 27 Repeat points 23 and 24. Then connect the ISAT tool and delete any trouble codes. Remove ISAT.
- 28 Move the top up and down 3 times. Check the function.

- 29 Fit the two threaded inserts into the Tonneau cover. These are fitted into the holes above the fifth bow locking motor. Use Torx bolts with washers and thread into the holes. Tighten to 3 - 4 Nm (2.20 - 2.95 lbf ft) or until they stop against the Tonneau cover.

Important

On cars from chassis number V7003161, these threaded inserts are already fitted.

- 30 Check that the six clips holding the cover plate are correctly fitted.

- 31 Attach the foam to the flat section of the top of the motor.

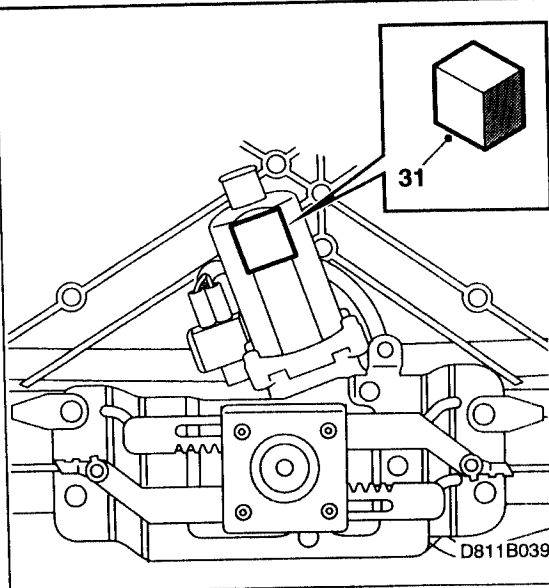
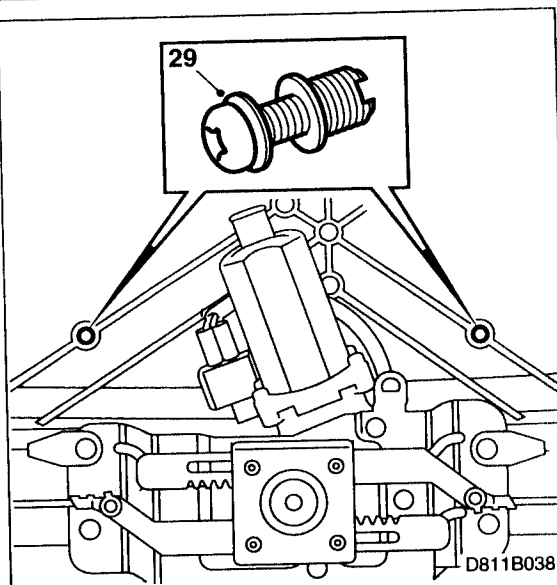
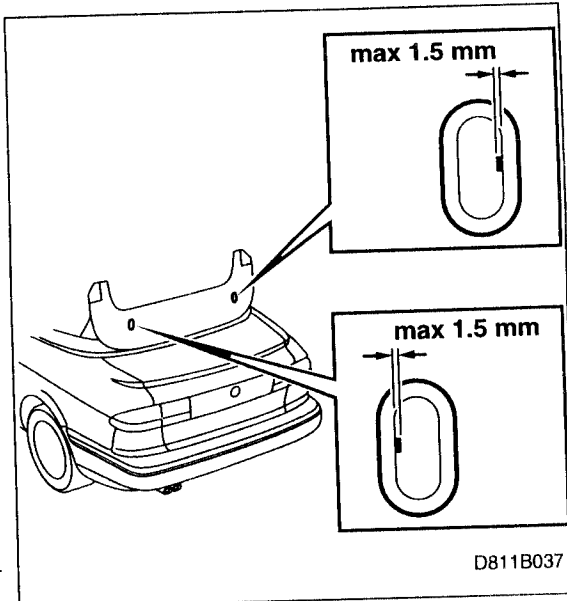

32 To mark the position of the hole on the cover plate, put a spot of paint or grease on the motor shaft.

Press the cover lightly into the clips. Using a center punch or awl, mark the position of the two holes to be drilled for the threaded inserts.

Press the cover lightly over the motor to mark the shaft position.

Remove the cover and check that the marks match the diagram.

Drill 2 x 6 mm holes for the threaded insert screws.

33 Use a 35 mm hole saw to cut a hole for the plastic plug.

34 Deburr the hole and fit the plastic plug.

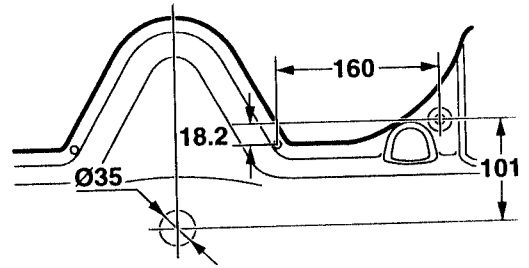

D811B040

35 Remove the protective paper from the tape and fit this to the plastic cover. This prevents scratch marks from the first bow.

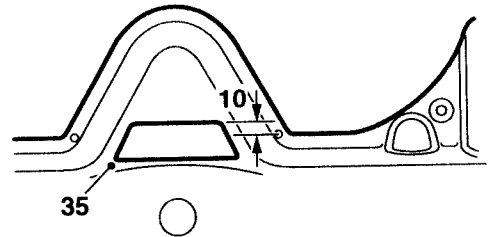

D811B041

36 Fit the plastic cover. First screw two new screws into the threaded inserts and then fit the original two bolts. Press in the clips on the cover starting from the center and working outward.

Warranty/Time information:

See separate information.

Stamping the Campaign Plate:

The campaign plate is not to be stamped for this campaign.

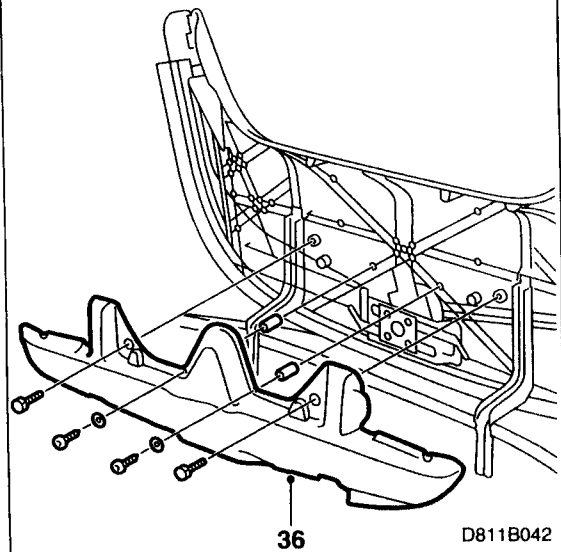

36

D811B042